

# 40,000 PPH 350 PSI RENTAL BOILER

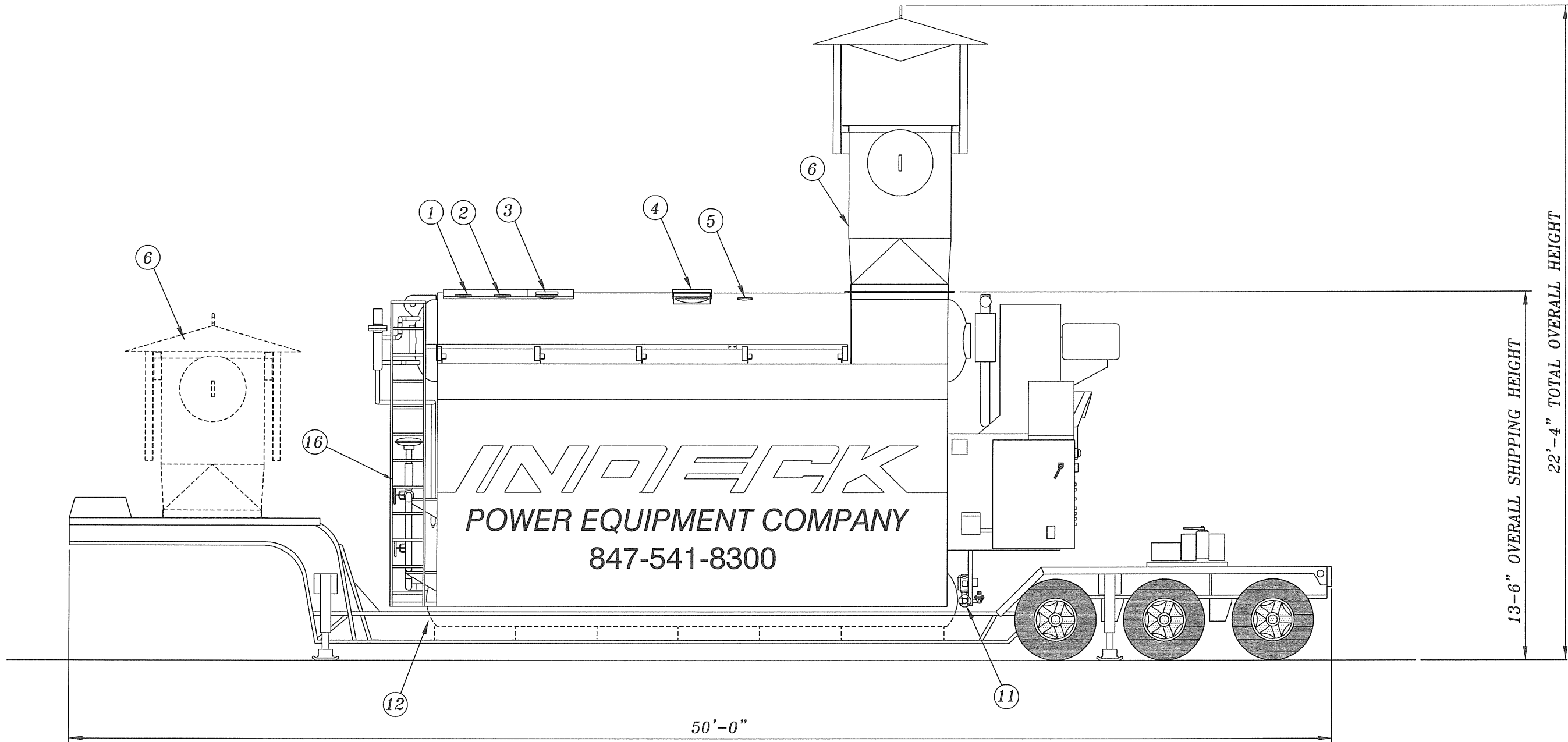

## INSTALLATION SERVICE CONNECTIONS

- |   |  |
|---|--|
| <ol style="list-style-type: none"> <li>1. 1 1/2"-300# SAFETY VALVE CONNECTION<br/>(SAFETY VALVE MUST BE REMOVED FOR TRANSPORT)</li> <li>2. 1 1/2"-300# SAFETY VALVE CONNECTION<br/>(SAFETY VALVE MUST BE REMOVED FOR TRANSPORT)</li> <li>3. 2-1/2"-300# SAFETY VALVE CONNECTION<br/>(SAFETY VALVE MUST BE REMOVED FOR TRANSPORT)<br/>(&amp; FOR LOW PRESSURE OPERATION ONLY)</li> <li>4. 6"-300 # MAIN STEAM OUTLET CONNECTION</li> <li>5. 1/2" NPT DRUM VENT / AUX CONNECTION</li> <li>6. FLUE GAS STACK AND TRANSITION<br/>(REMOVED FOR TRANSPORT)</li> <li>7. 1"-300# AUX ATOMIZING AIR / STEAM CONNECTION<br/>(LOCATED BEHIND CABINET)</li> <li>8. 1/2" NPT PILOT GAS CONNECTIONS (NAT OR PROPANE)</li> </ol> | <ol style="list-style-type: none"> <li>9. 3/4" NPT FUEL OIL RETURN CONN.<br/>(LOCATED ON OPPOSITE SIDE OF TRAILER)</li> <li>10. 1-1/2"-NPT FUEL OIL SUPPLY CONNECTION<br/>(LOCATED ON OPPOSITE SIDE OF TRAILER)</li> <li>11. 3"-150 # FUEL GAS CONNECTION</li> <li>12. 1-1/2"-300 # BLOW OFF CONNECTION</li> <li>13. 1-1/2"-300 # LOWER DRUM HEATING COIL CONNECTIONS</li> <li>14. 3/4" NPT CHEMICAL FEED CONNECTION</li> <li>15. 3/4" CONTINUOUS BLOWDOWN CONNECTION<br/>(LOCATED ON OPPOSITE SIDE OF TRAILER)</li> <li>16. 2" NPT FEEDWATER SUPPLY CONNECTION</li> <li>17. 460/60/3 POWER SUPPLY 150 AMPS</li> </ol> |
|---|--|

## DESIGN DATA

OVERALL LENGTH:	50'-0"
OVERALL WIDTH:	8'-6"
NET WEIGHT (INCL TRAILER):	66,000 LBS
CONTINUOUS CAPACITY:	40,000 PPH
DESIGN PRESSURE:	350 PSIG
FEEDWATER TEMPERATURE:	212 DEG F
FURNACE VOLUME:	601 CU. FT.
CONVECTION HEATING SURFACE:	2985 SQ. FT.
RADIANT HEATING SURFACE:	457 SQ. FT.
TOTAL HEATING SURFACE:	3442 SQ. FT. (A.S.M.E.)
GAS SUPPLY PRESSURE	6.5 PSIG (REGULATED BY CUSTOMER)
OIL SUPPLY PRESSURE	30 PSIG FLOODED MAX.
FEED WATER PRESSURE	60-100 PSIG ABOVE OPERATING PRESSURE

NOTE: A NATURAL GAS OR PROPANE PILOT IS REQUIRED FOR OIL

NOTE 2: PROVIDE ADEQUATE WEATHER PROTECTION FOR BURNER, CONTROLS AND PERSONNEL

**INDECK** 40,000 PPH RENTAL BOILER

INDECK POWER EQUIPMENT COMPANY 1111 WILLIS AVENUE · WHEELING, ILLINOIS 60090  
Ph. 847-541-8300 WWW.INDECK.COM