

60,000 PPH 395 PSI RENTAL BOILER

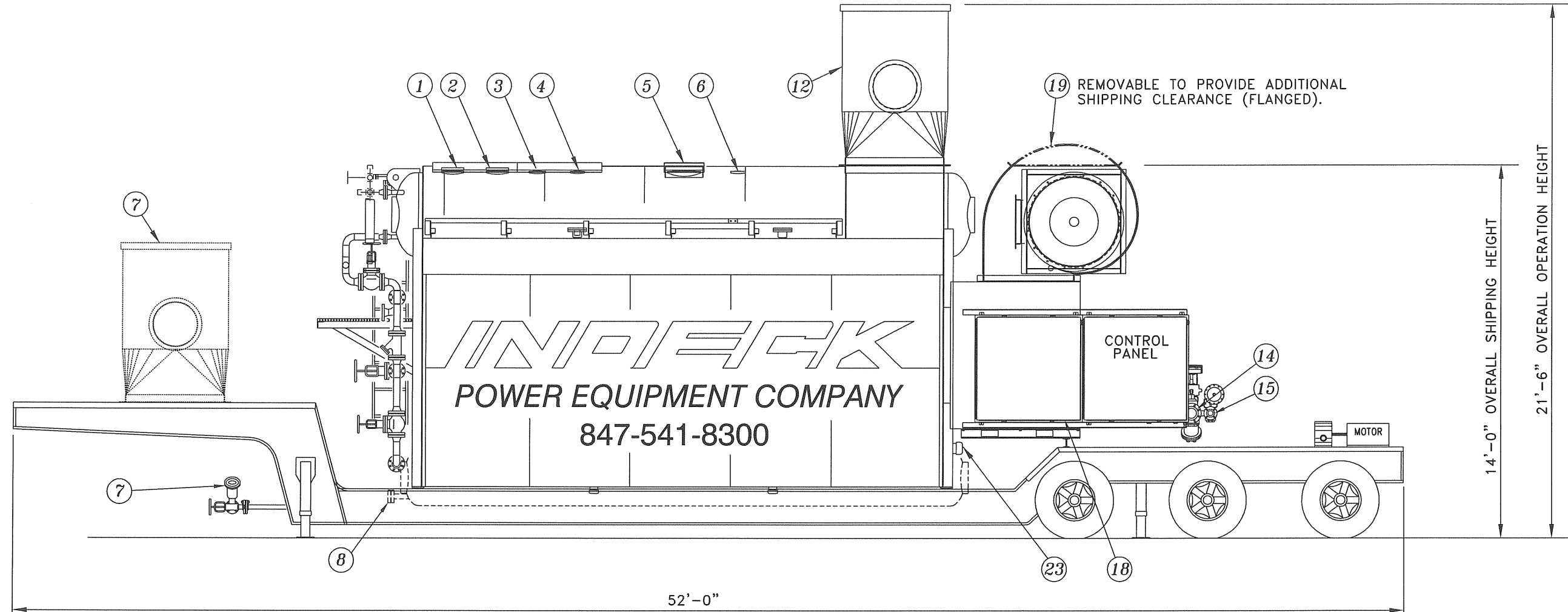

STEAM

1. 2 1/2"-600# SAFETY VALVE CONNECTION (SAFETY VALVE MUST BE REMOVED FOR TRANSPORT)
2. 2 1/2"-600# SAFETY VALVE CONNECTION (SAFETY VALVE MUST BE REMOVED FOR TRANSPORT)
3. 2"-600# SAFETY VALVE CONNECTION (SAFETY VALVE MUST BE REMOVED FOR TRANSPORT)
4. 2"-600# SAFETY VALVE CONNECTION (SAFETY VALVE MUST BE REMOVED FOR TRANSPORT)
5. 8"-300 # MAIN STEAM OUTLET CONNECTION
6. 1" NPT DRUM VENT / AUX CONNECTION
7. 1-1/2"-300# BLOW OFF CONNECTION
8. 1-1/2"-300# LOW DRUM HEATING COIL CONNECTIONS ARE BLANKED.
9. 1" CONTINUOUS BLOWDOWN CONNECTION
10. 2"-300# SOOT BLOWER STEAM SUPPLY CONNECTION (BLANK ON FAR SIDE)

BOILER FEEDWATER

11. 2-1/2"-300# FEEDWATER SUPPLY CONNECTION

FUEL GAS

12. FLUE GAS STACK AND TRANSITION (REMOVED FOR TRANSPORT)
13. 3/4" NPT PILOT GAS CONNECTIONS (NATURAL OR PROPANE)
14. 3"-150 # FUEL GAS CONNECTION
15. 1 1/2"-150 # GAS VENT OUTLET

FUEL OIL

16. 3/4" NPT FUEL OIL INLET (LOCATED ON FAR SIDE OF TRAILER)

ATOMIZING STEAM

17. 1 1/2"-300# AUX ATOMIZING AIR / STEAM CONNECTION (LOCATED BEHIND CABINET)

ELECTRICAL

18. 480/60/3 POWER SUPPLY 150 AMPS

MISC.

19. UPPER F.D. FAN HOUSING
20. 1" NPT CHEMICAL FEED CONNECTION (LOCATED ON OPPOSITE SIDE OF TRAILER)
21. 2"-300# CHEMICAL CLEANING CONNECTION
22. 3/4" NPT FURNANCE PRESS CONNECTION
23. WASHOUT
24. 1" NPT INSTRUMENT AIR CONNECTION

NOTE 1: A NATURAL GAS OR PROPANE PILOT IS REQUIRED FOR OIL

NOTE 2: PROVIDE ADEQUATE WEATHER PROTECTION FOR BURNER, CONTROLS AND PERSONNEL

DESIGN DATA

OVERALL LENGTH:	52'-0"
OVERALL WIDTH:	10'-6"
NET WEIGHT (INCL TRAILER):	90,000 LBS
CONTINUOUS CAPACITY:	60,000 PPH
DESIGN PRESSURE:	395 PSIG
FEEDWATER TEMPERATURE:	227 DEG F
FURNACE VOLUME:	799 CU. FT.
CONVECTION HEATING SURFACE:	3268 SQ. FT.
RADIANT HEATING SURFACE:	532 SQ. FT.
TOTAL HEATING SURFACE:	3800 SQ. FT. (A.S.M.E.)
GAS SUPPLY PRESSURE	15 PSIG (REGULATED BY CUSTOMER)
OIL SUPPLY PRESSURE	30 PSIG FLOODED MAX.
FEED WATER PRESSURE	75-100 PSIG ABOVE OPERATING PRESSURE
INSTRUMENT AIR PRESSURE	50 PSIG MIN. FEEDWATER TRAIN 80 TO 100 PSIG - FUELTRAIN

INDECK

INDECK POWER EQUIPMENT COMPANY
1111 WILLIS AVENUE · WHEELING, ILLINOIS 60090
Ph. 847-541-8300
WWW.INDECK.COM

60,000 PPH RENTAL BOILER

Rev D, 10-11-10 BCD