

UNIT REFERENCE:

TRAILER

94L

99L

100L

70,000 PPH 350 PSI RENTAL BOILER

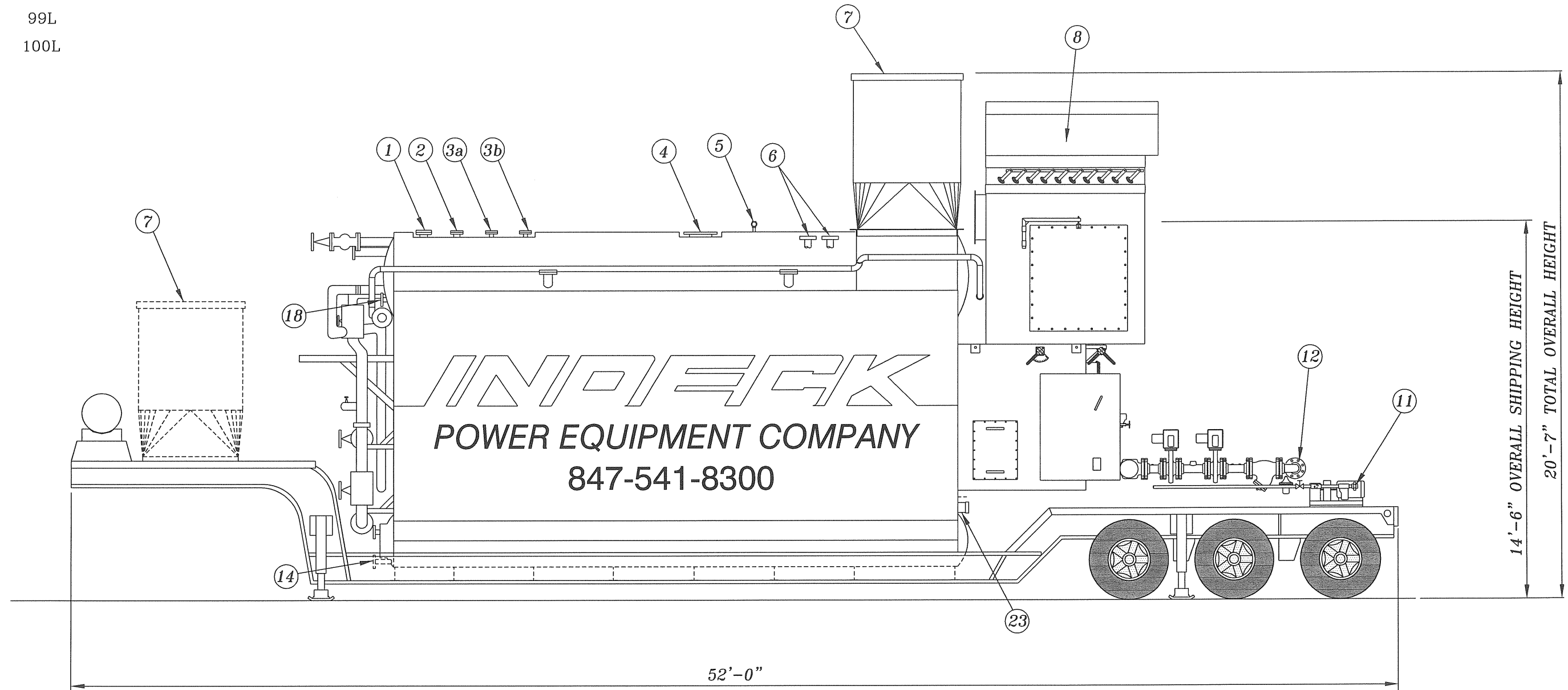

INSTALLATION SERVICE CONNECTIONS

1. 4"-300# SAFETY VALVE CONNECTION (SAFETY VALVE MUST BE REMOVED FOR TRANSPORT)
2. 4"-300# SAFETY VALVE CONNECTION (SAFETY VALVE MUST BE REMOVED FOR TRANSPORT)
- 3a. 2-1/2"-300# SAFETY VALVE CONNECTION (SAFETY VALVE MUST BE REMOVED FOR TRANSPORT)
- 3b. 2"-300# SAFETY VALVE CONNECTION (SAFETY VALVE MUST BE REMOVED FOR TRANSPORT)
4. 8"-300 # MAIN STEAM OUTLET CONNECTION
5. 1" NPT DRUM VENT / AUX CONNECTION
6. 2-1/2"-300 # OPTIONAL ECONOMIZER CONNECTIONS
7. FLUE GAS STACK AND TRANSITION (REMOVED FOR TRANSPORT)
8. UPPER F.D. FAN HOUSING (REMOVABLE TO PROVIDE ADDITIONAL SHIPPING CLEARANCE (FLANGED))
9. 1 1/2"-300# AUX ATOMIZING AIR / STEAM CONNECTION (LOCATED BEHIND CABINET)
10. 1/2" NPT PILOT GAS CONNECTIONS (NAT OR PROPANE)

11. 1-1/2" NPT FUEL OIL SUPPLY CONN. (LOCATED ON OPPOSITE SIDE OF TRAILER)
12. 4"-150 # FUEL GAS CONNECTION
13. 2"-150 # GAS VENT OUTLET
14. 1-1/2"-300 # BLOW OFF CONNECTION
15. 1-1/2"-300 # LOWER DRUM HEATING COIL CONNECTIONS
16. 1-1/4" NPT CHEMICAL FEED CONNECTION
17. 1" CONTINUOUS BLOWDOWN CONNECTION (LOCATED ON OPPOSITE SIDE OF TRAILER)
18. 2-1/2"-300 # FEEDWATER SUPPLY CONNECTION
19. 460/60/3 POWER SUPPLY 150 AMPS
20. 2"-300# SOOT BLOWER STEAM SUPPLY CONNECTION
21. 2"-300# CHEMICAL CLEANING CONNECTION
22. 1" NPT FURNANCE PRESS CONNECTION
23. WASHOUT
24. 1" NPT INSTRUMENT AIR CONNECTION

DESIGN DATA

OVERALL LENGTH:	52'-0"
OVERALL WIDTH:	10'-6"
NET WEIGHT (INCL TRAILER):	89,750 LBS
CONTINUOUS CAPACITY:	70,000 PPH
DESIGN PRESSURE:	350 PSIG
FEEDWATER TEMPERATURE:	240 DEG F
FURNACE VOLUME:	854 CU. FT.
CONVECTION HEATING SURFACE:	3647 SQ. FT.
RADIANT HEATING SURFACE:	620 SQ. FT.
TOTAL HEATING SURFACE:	4267 SQ. FT. (A.S.M.E.)
GAS SUPPLY PRESSURE	10 PSIG (REGULATED BY CUSTOMER)
OIL SUPPLY PRESSURE	30 PSIG FLOODED MAX.
FEED WATER PRESSURE	75-100 PSIG ABOVE OPERATING PRESSURE
INSTRUMENT AIR PRESSURE	50 PSIG MIN.

- NOTE: A NATURAL GAS OR PROPANE PILOT IS REQUIRED FOR OIL
- NOTE 2: PROVIDE ADEQUATE WEATHER PROTECTION FOR BURNER, CONTROLS AND PERSONNEL

INDECK 70,000 PPH RENTAL BOILER

INDECK POWER EQUIPMENT COMPANY 1111 WILLIS AVENUE · WHEELING, ILLINOIS 60090
Ph. 847-541-8300 WWW.INDECK.COM