

UNIT REFERENCE:
 39L 14-00126
 41L 14-00129
 42L 14-00127
 43L 14-00128

30,000 PPH RENTAL BOILER

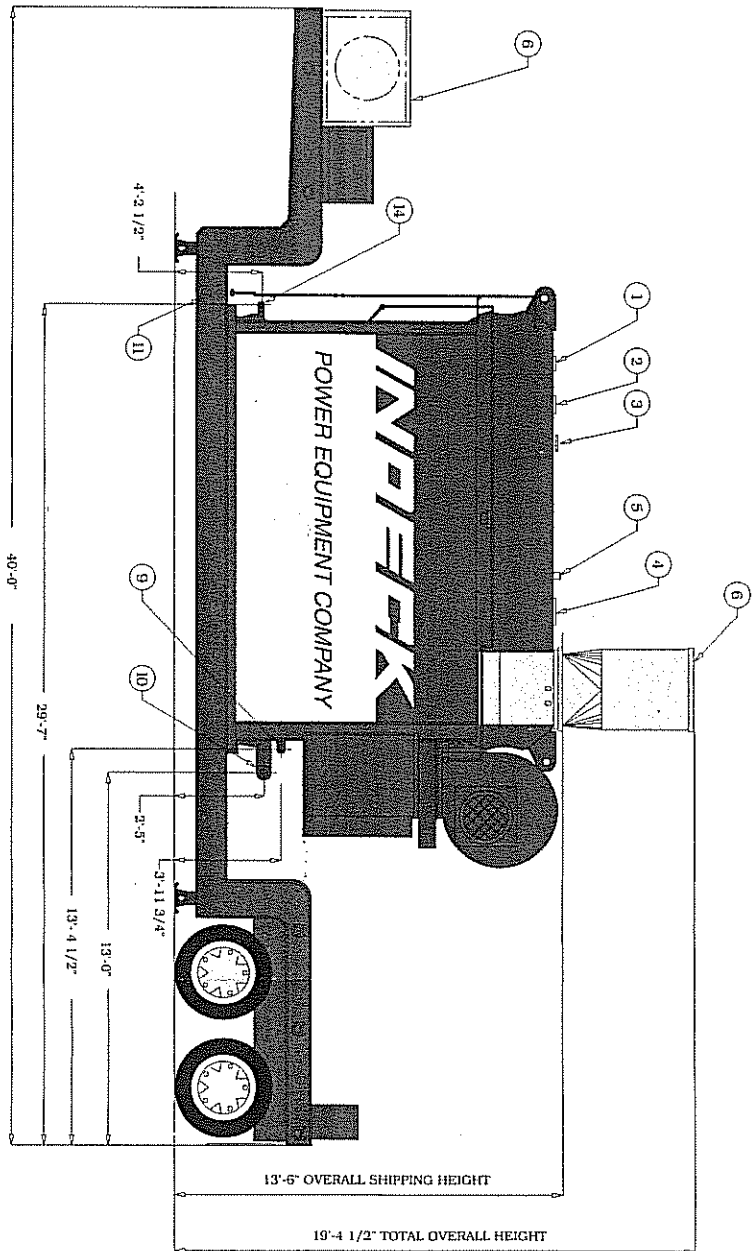

INSTALLATION SERVICE CONNECTIONS

1. 2"-300# SAFETY VALVE CONNECTION
2. SAFETY VALVE MUST BE REMOVED FOR TRANSPORT
3. 2"-300# SAFETY VALVE CONNECTION
4. SAFETY VALVE MUST BE REMOVED FOR TRANSPORT
5. SAFETY VALVE MUST BE REMOVED FOR TRANSPORT
6. SAFETY VALVE MUST BE REMOVED FOR TRANSPORT
7. SAFETY VALVE MUST BE REMOVED FOR TRANSPORT
8. SAFETY VALVE MUST BE REMOVED FOR TRANSPORT
9. SAFETY VALVE MUST BE REMOVED FOR TRANSPORT
10. SAFETY VALVE MUST BE REMOVED FOR TRANSPORT
11. SAFETY VALVE MUST BE REMOVED FOR TRANSPORT
12. SAFETY VALVE MUST BE REMOVED FOR TRANSPORT
13. SAFETY VALVE MUST BE REMOVED FOR TRANSPORT
14. SAFETY VALVE MUST BE REMOVED FOR TRANSPORT
15. SAFETY VALVE MUST BE REMOVED FOR TRANSPORT

DESIGN DATA

9. 1 1/2" NPT FUEL OIL SUPPLY CONNECTION
 10. 3"-150# FLANGE FUEL GAS CONNECTION (FEMALE)
 11. 1 1/2" NPT BLOW OFF GAS CONNECTION
 12. 1" CONTINUOUS BLOW OFF CONNECTION
 13. 1" CONTINUOUS BLOW OFF CONNECTION
 14. 1 1/2" NPT PREHEATER SUPPLY CONNECTION (FEMALE)
 15. 480/60/3 POWER SUPPLY 60 AMP
- OVERALL LENGTH: 40'-0"
 OVERALL WIDTH: 8'-0"
 NET WEIGHT (INCL. TRAILER): 56,035 LBS
 CONTINUOUS CAPACITY: 30,000 PPH
 DESIGN PRESSURE: 300 PSIG
 DESIGN TEMPERATURE: 520 DEG F
 RADIANT HEATING SURFACE: 4777 SQ. FT.
 TOTAL HEATING SURFACE: 651 SQ. FT. (A.S.M.E.)
 GAS SUPPLY PRESSURE: 2561 SQ. FT. (A.S.M.E.)
 OIL SUPPLY PRESSURE: 8.0 PSIG (REGULATED BY CUSTOMER)
 FLOODED TO 30 PSIG MAX.
 FEED WATER PRESSURE: 60-100 PSI ABOVE OPERATING PRESSURE

NOTE 1: A NATURAL GAS OR PROPANE PILOT IS REQUIRED FOR OIL.
 NOTE 2: PROVIDE ADEQUATE WEATHER PROTECTION FOR BURNER, CONTROLS, AND PERSONNEL.

C.F. NO. TRAILER30-300