

**UNIT REFERENCE:**

TRAILER 220L  
TRAILER 221L

# 40,000 PPH 395 PSI RENTAL BOILER

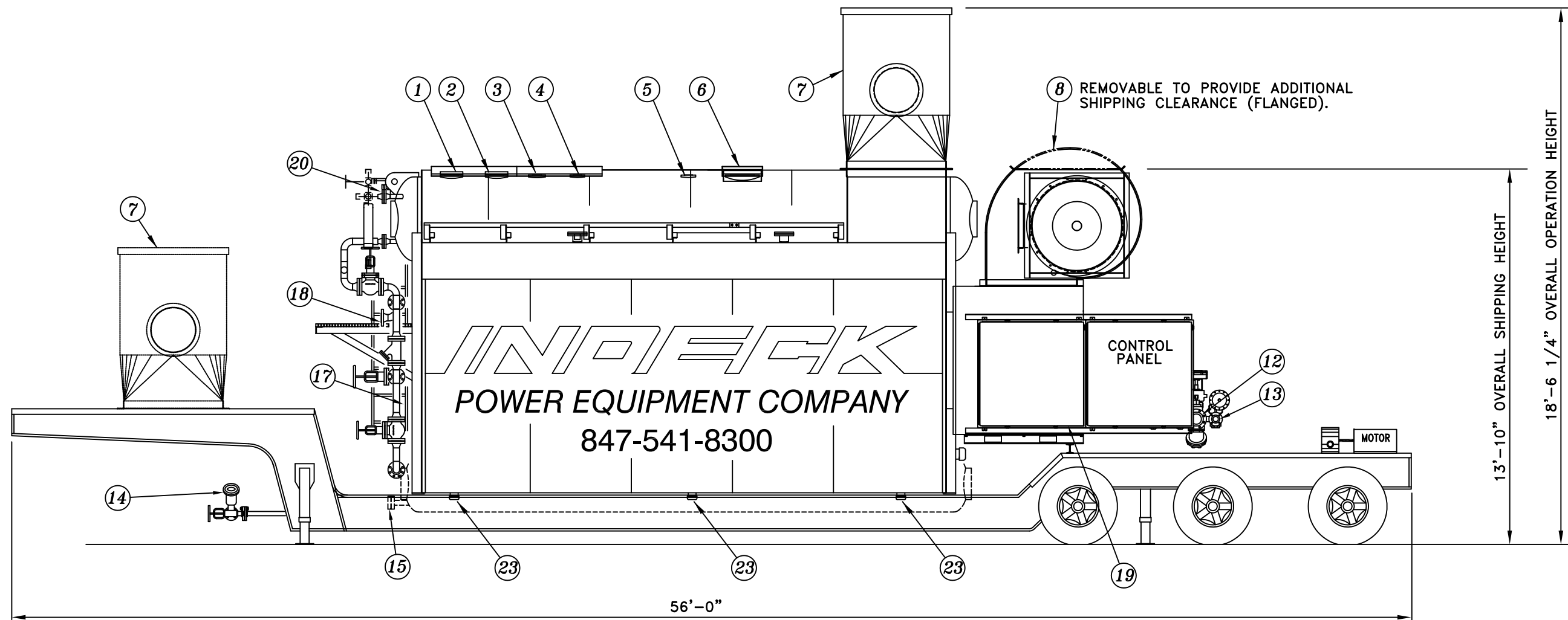

**STEAM**

1. 2"-600# SAFETY VALVE CONNECTION (SPARE BLANKED)
2. 2"-600# SAFETY VALVE CONNECTION (SPARE BLANKED)
3. 1 1/2"-600# SAFETY VALVE CONNECTION (SAFETY VALVE MUST BE REMOVED FOR TRANSPORT)
4. 1 1/2"-600# SAFETY VALVE CONNECTION (SAFETY VALVE MUST BE REMOVED FOR TRANSPORT)
5. 1" NPT DRUM VENT / AUX CONNECTION
6. 8"-300 # MAIN STEAM OUTLET CONNECTION
14. 1-1/2"-300# BLOW OFF CONNECTION
15. (2) 1-1/2"-300# LOW DRUM HEATING COIL CONNECTIONS ARE BLANKED.
17. 1" NPT CONTINUOUS BLOWDOWN CONNECTION
20. 2"-300# SOOT BLOWER STEAM SUPPLY CONNECTION (BLANK ON FAR SIDE)

**BOILER FEEDWATER**

18. 2"-300# FEEDWATER SUPPLY CONNECTION

**FUEL GAS**

10. 3/4" NPT PILOT GAS CONNECTIONS (NATURAL OR PROPANE)
12. 3"-150 # FUEL GAS CONNECTION
13. 1 1/2"-150 # GAS VENT OUTLET

**FUEL OIL**

11. 3/4" NPT FUEL OIL INLET (LOCATED ON FAR SIDE OF TRAILER)

**ATOMIZING STEAM**

9. 1"-300# AUX ATOMIZING AIR / STEAM CONNECTION (LOCATED BEHIND CABINET)

**ELECTRICAL**

19. 480/60/3 POWER SUPPLY 150 AMPS

**MISC.**

7. FLUE GAS STACK AND TRANSITION (REMOVED FOR TRANSPORT)
8. UPPER F.D. FAN HOUSING
16. 1" NPT CHEMICAL FEED CONNECTION (LOCATED ON OPPOSITE SIDE OF TRAILER)
21. N/A
22. 3/4" NPT FURNANCE PRESS CONNECTION
23. (3) 1 1/2" WASHOUT (CAPPED)
24. 1" NPT INSTRUMENT AIR CONNECTION

NOTE 1: A NATURAL GAS OR PROPANE PILOT IS REQUIRED FOR OIL

NOTE 2: PROVIDE ADEQUATE WEATHER PROTECTION FOR BURNER, CONTROLS AND PERSONNEL

**DESIGN DATA**

OVERALL LENGTH:	56'-0"
OVERALL WIDTH:	8'-6"
NET WEIGHT (INCL TRAILER):	83,000 LBS
CONTINUOUS CAPACITY:	40,000 PPH
DESIGN PRESSURE:	395 PSIG
FEEDWATER TEMPERATURE:	227 DEG F(GAS)-240 DEG F(OIL)
FURNACE VOLUME:	594 CU. FT.
CONVECTION HEATING SURFACE:	2374.5 SQ. FT.
RADIANT HEATING SURFACE:	502.2 SQ. FT.
TOTAL HEATING SURFACE:	2876.7 SQ. FT.
GAS SUPPLY PRESSURE:	15 PSIG (REGULATED BY CUSTOMER)
OIL SUPPLY PRESSURE:	30 PSIG FLOODED MAX.
FEED WATER PRESSURE:	75-100 PSIG ABOVE OPERATING PRESSURE
INSTRUMENT AIR PRESSURE:	80 TO 100 PSIG

**INDECK** 40,000 PPH RENTAL BOILER

INDECK POWER EQUIPMENT COMPANY  
1111 WILLIS AVENUE · WHEELING, ILLINOIS 60090  
Ph. 847-541-8300  
WWW.INDECK.COM