

60,000 PPH 350 PSI RENTAL BOILER

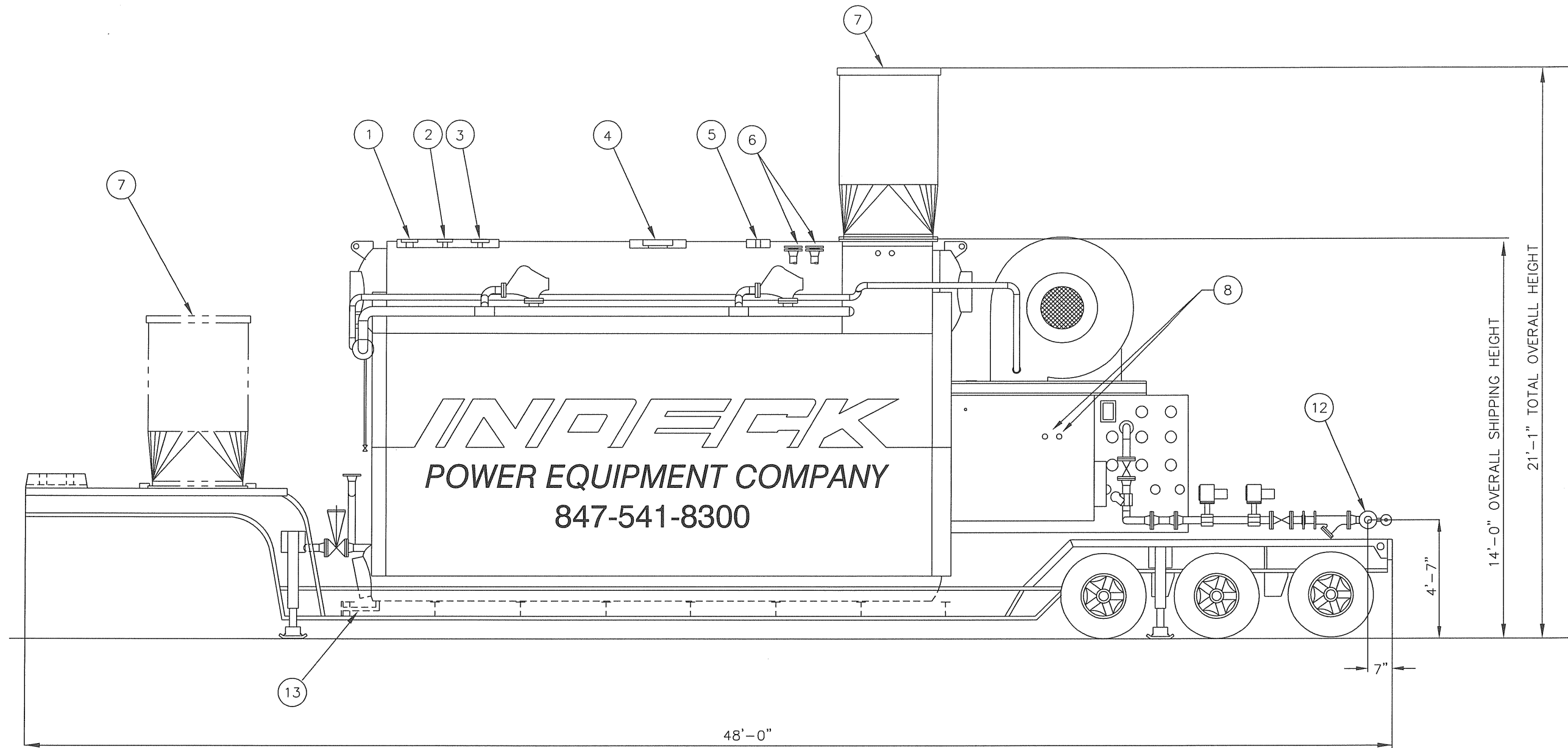

INSTALLATION SERVICE CONNECTIONS

1. 3" 300# SAFETY VALVE CONNECTION
(SAFETY VALVE MUST BE REMOVED FOR TRANSPORT)
2. 3" 300# SAFETY VALVE CONNECTION
(SAFETY VALVE MUST BE REMOVED FOR TRANSPORT)
3. 3" 300# SAFETY VALVE CONNECTION
(SAFETY VALVE MUST BE REMOVED FOR TRANSPORT)
(& FOR LOW PRESSURE OPERATION ONLY)
4. 8" 300# MAIN STEAM OUTLET CONNECTION
5. 1" NPT DRUM VENT / AUX CONNECTION
6. 2-1/2"-300 # OPTIONAL ECONOMIZER CONNECTIONS
7. FLUE GAS STACK AND TRANSITION
(REMOVED FOR TRANSPORT)
8. 1 1/4" NPT AUX ATOMIZING AIR / STEAM CONNECTION
(LOCATED BEHIND CABINET)
9. 1/2" NPT PILOT GAS CONNECTIONS (NAT OR PROPANE)
10. 3/4" NPT FUEL OIL RETURN CONNECTION
(LOCATED ON OPPOSITE SIDE OF TRAILER)
11. 1-1/2"-NPT FUEL OIL SUPPLY CONNECTION
(LOCATED ON OPPOSITE SIDE OF TRAILER)
12. 3" 300# FUEL GAS CONNECTION
13. 1-1/2"-300# BLOW OFF CONNECTION
14. 3/4" NPT CHEMICAL FEED CONNECTION
15. 1" CONTINUOUS BLOWDOWN CONNECTION
(LOCATED ON OPPOSITE SIDE OF TRAILER)
16. 3" 300# FEEDWATER SUPPLY CONNECTION
17. 460/60/3 POWER SUPPLY 150 AMPS

DESIGN DATA

OVERALL LENGTH:	48'-0"
OVERALL WIDTH:	10'-6"
NET WEIGHT (INCL TRAILER):	84,500 LBS
CONTINUOUS CAPACITY:	60,000 LBS/HR
DESIGN PRESSURE:	350 PSIG
FEEDWATER TEMPERATURE:	220 DEG F
FURNACE VOLUME:	854 CU. FT.
CONVECTION HEATING SURFACE:	3647 SQ. FT.
RADIANT HEATING SURFACE:	620 SQ. FT.
TOTAL HEATING SURFACE:	4267 SQ. FT. (A.S.M.E.)
GAS SUPPLY PRESSURE	10 PSI REGULATED (BY CUSTOMER)
OIL SUPPLY PRESSURE	FLOODED TO 30 PSI MAX.
FEED WATER PRESSURE	60-100 PSIG ABOVE OPERATING PRESSURE

NOTE (1): A NATURAL GAS OR PROPANE PILOT IS REQUIRED FOR OIL

NOTE (2): PROVIDE ADEQUATE WEATHER PROTECTION FOR BURNER, CONTROLS, AND PERSONNEL

INDECK 60,000 PPH RENTAL BOILER

INDECK POWER EQUIPMENT COMPANY 1111 WILLIS AVENUE · WHEELING, ILLINOIS 60090
Ph. 847-541-8300 WWW.INDECK.COM