

75,000 PPH SUPERHEAT RENTAL BOILER

DESIGN & OPERATING DATA

Indeck Boiler Model	OT-75-SR1
Continuous Capacity with Economizer	75,000 PPH
Design Pressure	750 PSIG
Design Temperature	750 degF
Operating Pressure (NRV Outlet)	300 - 675 PSIG
Feedwater Pressure	75-80 PSIG Above Operating Pressure
Feedwater Temperature (to Economizer)	230 degF
Natural Gas Supply Pressure	12-15 PSIG (Constant Regulation)
Oil Pump Inlet Pressure	Positive to 30 PSIG MAX. Flooded
Alternate Pilot Gas Pressure	10 PSIG (When firing #2 oil, Regulated)
Instrument Air Pressure	60-80 PSIG

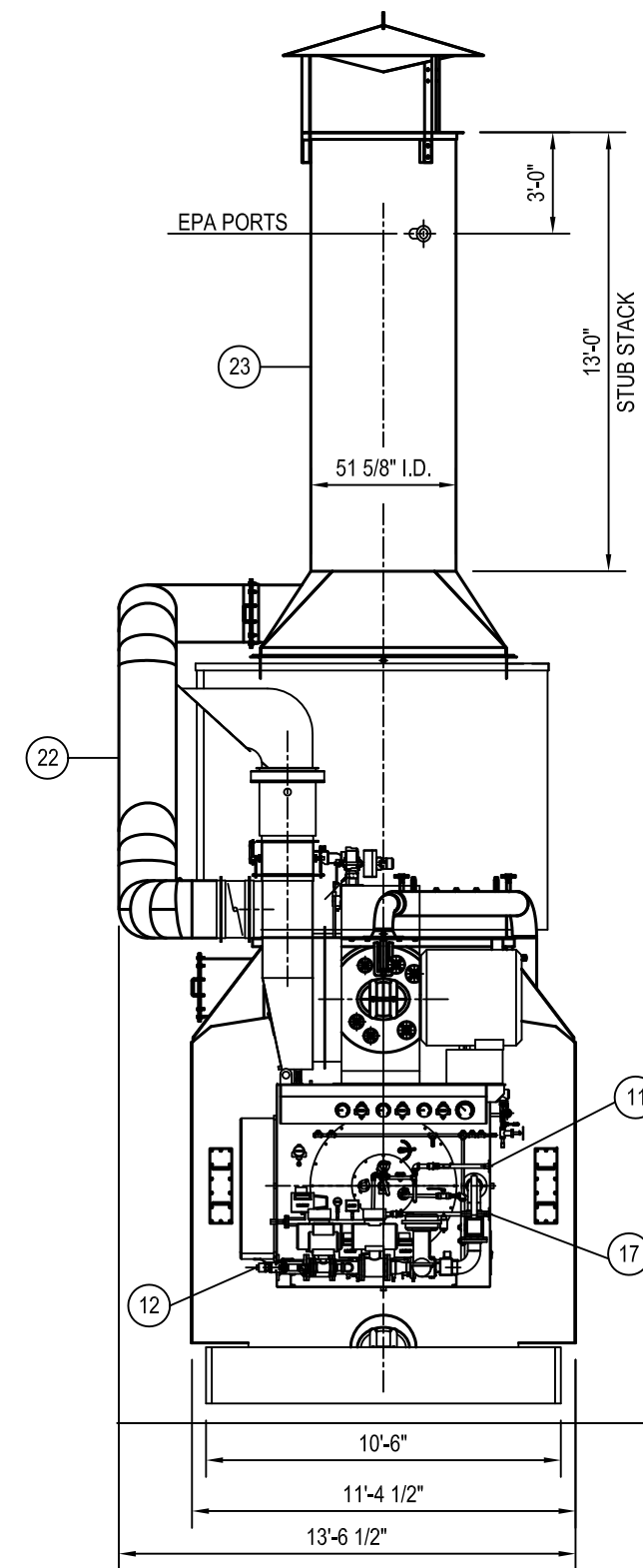
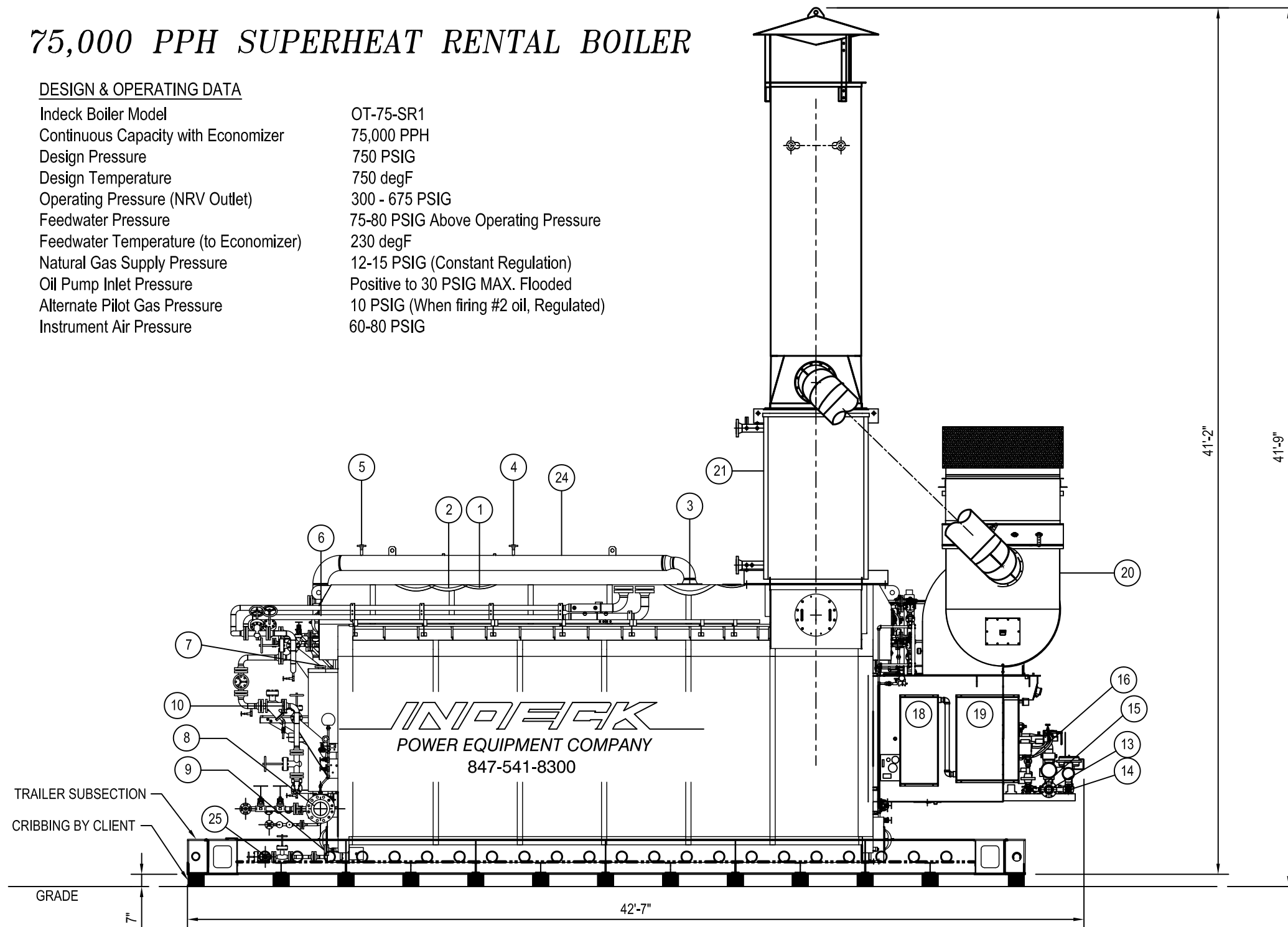

STEAM

1. 2-1/2" 600# Safety Valve*
2. 2" 600# Safety Valve*
3. 6" 600# Drum Steam Outlet
4. 1" 600# Steam Sampling*
5. 1" 600# Crossover Vent*
6. 8" 600# Superheater Inlet
7. 1-1/2" 600# Superheater Safety Valve*
8. 8" 600# Superheater Product Outlet
9. (2) 1 1/2" 600# Mud Drum Heating Coil (In/Out)

BOILER FEEDWATER

10. 2-1/2" 600# Feedwater Supply Connection (Economizer piping shipped loose)

BURNER / FUEL TRAINS (Nat Gas or #2 Oil Fired)

11. 1" 150# Atomizing Air Inlet (Atomizing steam is prepiped from steam drum)
12. 1" NPT Alternate Pilot Gas Inlet (Propane or Natural Gas)
13. 4" 150# Natural Gas Inlet Connection
14. 2" 150# Natural Gas Vent
15. 3/4" NPT Pilot Gas Regulator Vent
16. 1" NPT Pilot Gas Train Vent Fuel Oil
17. 1" 150# #2 Fuel Oil inlet (Portable valve train and pump skid not shown)

POWER DISTRIBUTION & CONTROLS

18. Electrical Power Distribution Cabinet - 480V/60HZ/3ph Power Supply
19. Burner Management & Combustion Control Cabinet

MISCELLANEOUS

20. FD Fan - Motor - Silencer - FGR Mixbox - Dampers - Expansion Joint*
21. Economizer - Associated Piping - Safety Valve - Vent - Drain*
22. FGR Ductwork - Damper - Expansion Joint*
23. Flue Gas Stack with Integral Transition - Raincap*
24. Saturated Steam Crossover Pipe*
25. (2) Mud Drum Blowdown Valves*
26. #2 Fuel Oil Pump System (not represented)*

NOTES

1. Items marked with "*" are shipped loose. Additional items also shipped loose.
2. Firing unit on #2 fuel oil requires natural gas or vaporous propane pilot fuel to be supplied by client.
3. Client to provide adequate weather protect for burner, controls and personnel. This includes freeze protection.
4. Client is responsible for heat tracing and insulating feedwater piping and steam crossover pipe for personnel and freeze protection.
5. Spare steam drum safety valve and vent connections available.
6. Client responsible for determining trailer cribbing material and method. Drawing representation if for reference only.

INDECK 75,000 PPH RENTAL BOILER