

PRESSURIZED ASME-CODE RECEIVER - 50 PSIG @ 450 F
ALL CS SURFACES EXTERNALLY - EPOXY COATED

TANK CAPACITY = 2200 GALLONS
CAPACITY TO OVERFLOW = 1750 GALLONS

A108 SCH. 40 CS PIPE EXCEPT CONDENSATE LINES SCH. 80
RF FLG 50 A105 XS - UP TO 1 1/2"
RF 50 FLD A105 - 2" AND ABOVE
CL 3000 SW OR NPT FITTINGS - UP TO 2"

THRD HEX HEAD A105 CS PLUG
BRANCH COUPLING A105 CL 3000 - UP TO 2"
SCH. 80 1/2" AND 1" NPT/A105
ZINC COATED BOLTS
GASKETS - 304SS / GRAFON SPIRAL WOUND
ALL STEEL PIPING PRIMED & EPOXY COATED

6" WIDE FLANGE I-BEAM STRUCTURAL STEEL BASE
4" WIDE FLANGE I-BEAM UPRIGHT SUPPORTS
6"x6" SQUARE ANCHOR SUPPORT GUSSETS
ALL STRUCTURAL STEEL PRIMED & EPOXY COATED

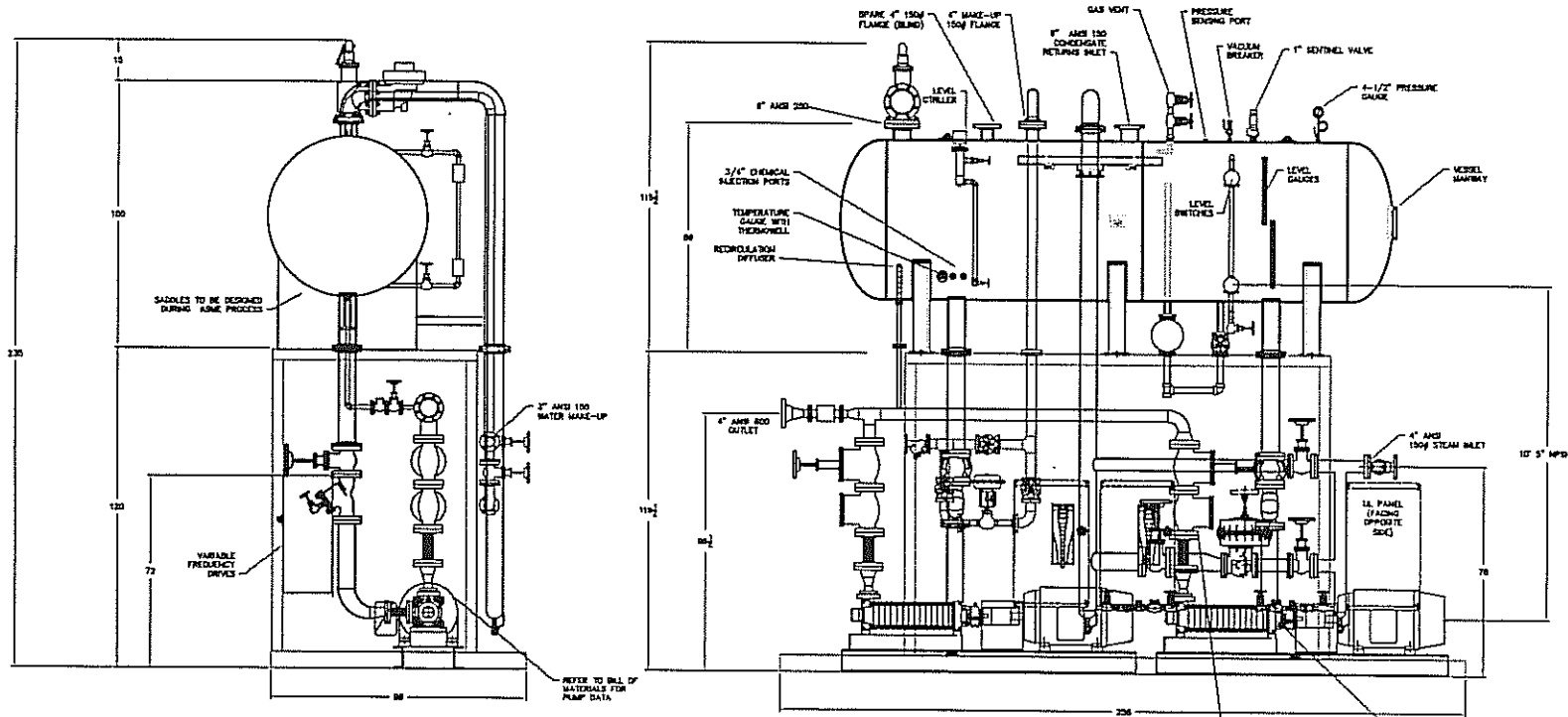

- NOTES:
1. COMPLETE STRUCTURAL STEEL VERTICAL SUPPORTS, NOT SHOWN, SUPPORTS ARE PROVIDED FOR PUMP SUCTION AND DISCHARGE PIPING.
 2. ELECTRICAL WIRING AND CONDUIT, NOT SHOWN.
 3. PRESSURE GAUGES WITH ISOLATION VALVES, INSTALLED ON PUMP DISCHARGE AND RECEIVER.
 4. UL-LISTED ELECTRICAL CONTROL PANEL, NEMA 3R 480 VOLT 3 PHASE, DETAILS NOT SHOWN.
 5. ALL DIMENSIONS ARE IN INCHES, ACTUAL DIMENSIONS MAY VARY.
 6. LEVEL GAUGE INCLUDED AS SHOWN.
 7. APPROXIMATE WEIGHT IS 15,000 LBS.
 8. ACTUAL PACKAGE CONSTRUCTION MAY VARY FROM SPECIFICATIONS BASED ON MANUFACTURING REQUIREMENTS AND STANDARDS. ACCEPTANCE OF SUBMITTAL AUTHORIZES MANUFACTURER BASED ON SUBMITTAL.
 9. COMPLETE PACKAGE SHALL BE UL-LISTED WITH ENVIROSEP SS NAMEPLATE AND SS UL NAMEPLATE. ID TAGS SHALL BE PLACED ON STRUCTURAL FRAME.

INDEX POWER
DEAERATOR PACKAGE
80,000 #/HR @
500 TO 850 PSIG OUTPUT
(2) UNITS REQUIRED

SS UL NAMEPLATE INFO:
MODEL # 2600-DA-S
S/N - 8060062-3/4

CERTIFIED
SUBMITTAL

NO.	REVISION	DATE	BY	CHKD.	APP. STATE	DESCRIPTION
1	GENERAL CHANGES					
2	LAYOUT AND PUMPS					
3	REVISION					

ACAD NAME: _____

DATE: _____

BY: _____

CHKD.: _____

APP. STATE: _____

DESCRIPTION: THE DRAWING IS A PRIVATE AND CONFIDENTIAL DOCUMENT AND THE PROPERTY OF THE DRAWER. IT IS TO BE KEPT IN STRICTLY CONFIDENTIALITY AND NOT TO BE REPRODUCED OR COPIED IN ANY MANNER WITHOUT THE WRITTEN PERMISSION OF THE DRAWER.

SCALE: AS SHOWN

DATE: _____

BY: _____

CHKD.: _____

APP. STATE: _____

PROJ. NUMBER 8060062	TITLE DEAERATOR & PUMP PACKAGE LAYOUT AND SIZING
SCALE	
DRAWING NUMBER 8060062	SHEET NUMBER 2 OF 2
	REV. 2