

# 24,000 PPH 300 PSI RENTAL BOILER

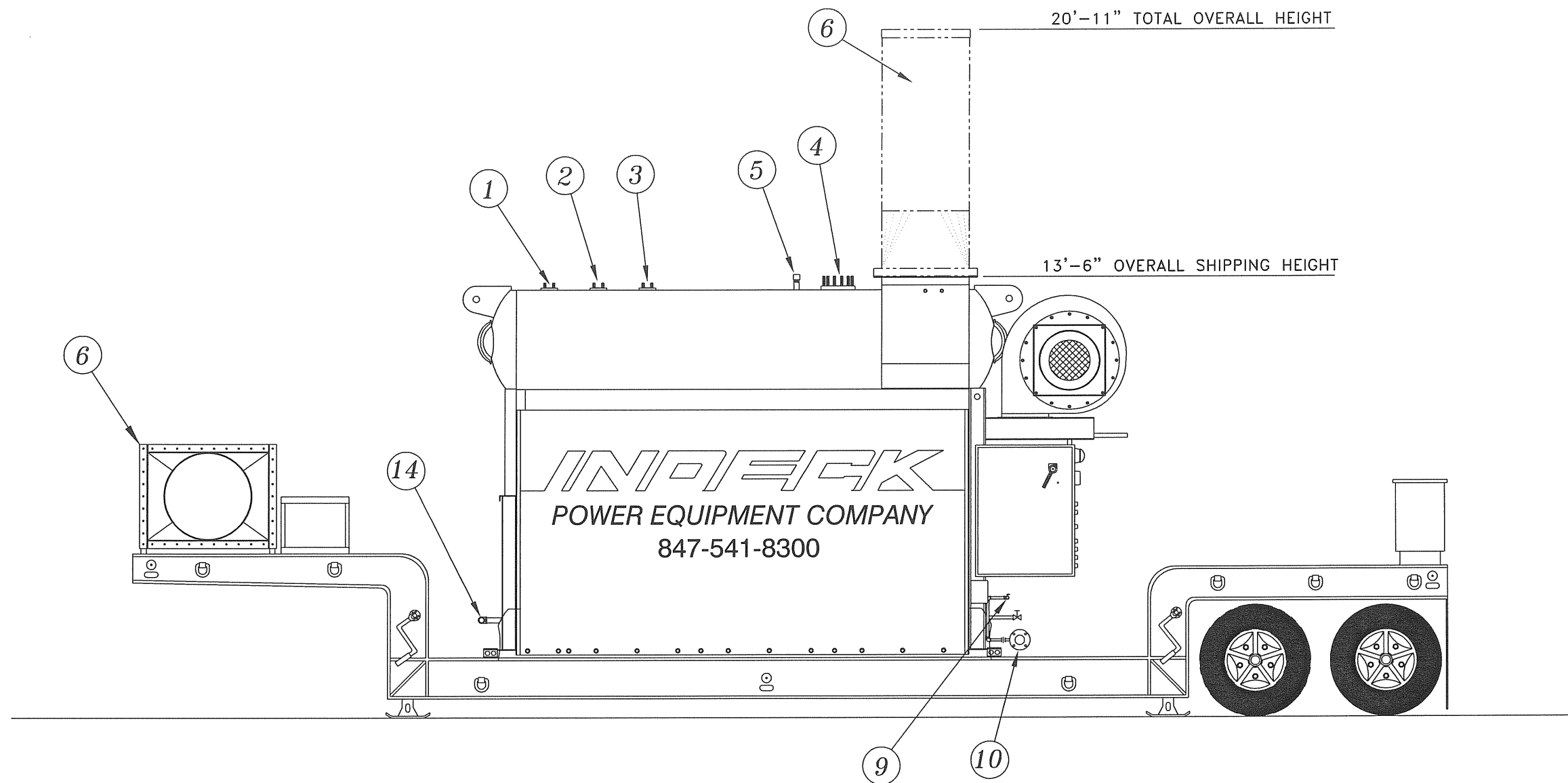

## INSTALLATION SERVICE CONNECTIONS

- |  |   |
|--|---|
| <ol style="list-style-type: none"> <li>1. 1 1/2"-300# SAFETY VALVE CONNECTIONS<br/>(SAFETY VALVE MUST BE REMOVED FOR TRANSPORT)</li> <li>2. 1 1/2"-300# SAFETY VALVE CONNECTIONS<br/>(SAFETY VALVE MUST BE REMOVED FOR TRANSPORT)</li> <li>3. 1 1/2" FLANGED SAFETY VALVE CONNECTION<br/>(SAFETY VALVE MUST BE REMOVED FOR TRANSPORT)</li> <li>4. 6"-300 # MAIN STEAM OUTLET CONNECTION</li> <li>5. 1 1/2" NPT DRUM VENT / AUX CONNECTION</li> <li>6. FLUE GAS STACK AND TRANSITION<br/>(REMOVED FOR TRANSPORT)</li> <li>7. 3/4" NPT AUX ATOMIZING / STEAM CONNECTION<br/>(LOCATED BEHIND CABINET)</li> <li>8. 1/2" NPT PILOT GAS CONNECTIONS (NAT OR PROPANE)<br/>(LOCATED BEHIND CABINET)</li> </ol> | <ol style="list-style-type: none"> <li>9. 1 1/2" NPT FUEL OIL SUPPLY CONNECTION</li> <li>10. 3"-150 # FLANGED FUEL GAS CONNECTION</li> <li>11. 1-1/2"-300 # BLOW OFF CONNECTION<br/>(LOCATED ON OPPOSITE SIDE OF TRAILER)</li> <li>12. 3/4" NPT CHEMICAL FEED CONNECTION</li> <li>13. 3/4" CONTINUOUS BLOWDOWN CONNECTION<br/>(LOCATED ON OPPOSITE SIDE OF TRAILER)</li> <li>14. 1-1/2"- FEEDWATER SUPPLY CONNECTION (FEMALE)</li> <li>15. 460/60/3 POWER SUPPLY 60 AMPS</li> </ol> |
|--|---|

## DESIGN DATA

OVERALL LENGTH:	40'-0"
OVERALL WIDTH:	8'-0"
NET WEIGHT (INCL TRAILER):	51,793 LBS
CONTINUOUS CAPACITY:	24,000 PPH
DESIGN PRESSURE:	300 PSIG
FEEDWATER TEMPERATURE:	220 DEG F
FURNACE VOLUME:	962 CU. FT.
CONVECTION HEATING SURFACE:	4777 SQ. FT.
RADIANT HEATING SURFACE:	651 SQ. FT.
TOTAL HEATING SURFACE:	2109 SQ. FT. (A.S.M.E.)
GAS SUPPLY PRESSURE	8.0 PSIG (REGULATED BY CUSTOMER)
OIL SUPPLY PRESSURE	30 PSIG FLOODED MAX.
FEED WATER PRESSURE	60-100 PSIG ABOVE OPERATING PRESSURE

NOTE: A NATURAL GAS OR PROPANE PILOT IS  
REQUIRED FOR OIL  
NOTE 2: PROVIDE ADEQUATE WEATHER  
PROTECTION FOR BURNER, CONTROLS  
AND PERSONNEL

**INDECK** 24,000 PPH RENTAL BOILER

INDECK POWER EQUIPMENT COMPANY 1111 WILLIS AVENUE WHEELING, ILLINOIS 60090  
Ph. 847-541-8300 WWW.INDECK.COM